

## STREAMLINE • CONSOLE

REF. STREAMLINE

### WEIGHT

Net Weight: 130kg | 286.6 lbs  
 Gross Weight: 169kg | 372.6 lbs

### MATERIALS

Top: Marble | Wood  
 Body: Brass | Iron

### PACKING (approx.)

Dimensions: 141 x 78 x 63 cm  
 55.5 x 30.7 x 24.8 in

Volume: 0.69 m<sup>3</sup> | 24.47 ft<sup>3</sup>

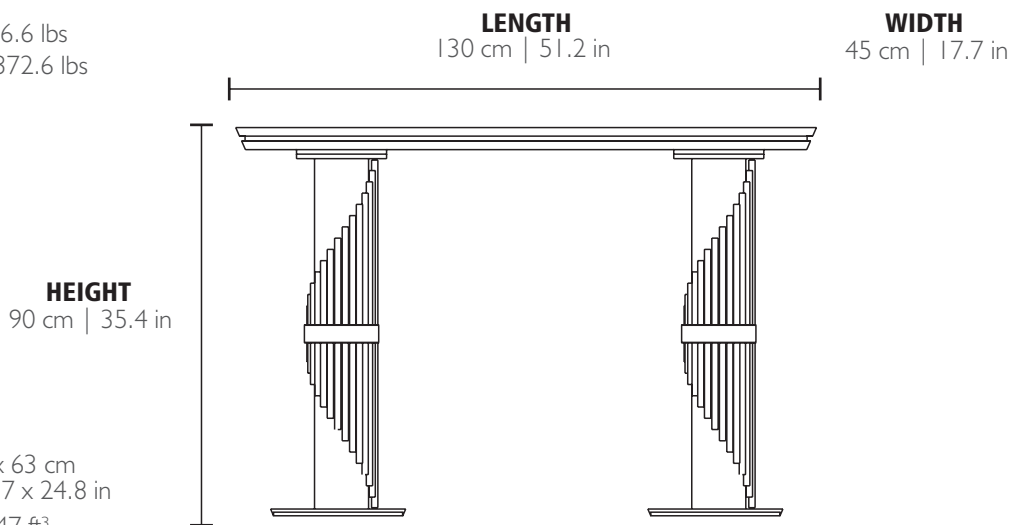

☐ - Products manufactured according the European norm of security EN 60 598-1.

▽ - Products adjusted for installation in surfaces normally inflammable.

☐ - Products of class II. The electric isolation is double or reinforced.

⚡ - Products with the possibility of installation of low-energy consumption bulbs.

## PRODUCT FINISHES & COSTUMIZATION OPTIONS

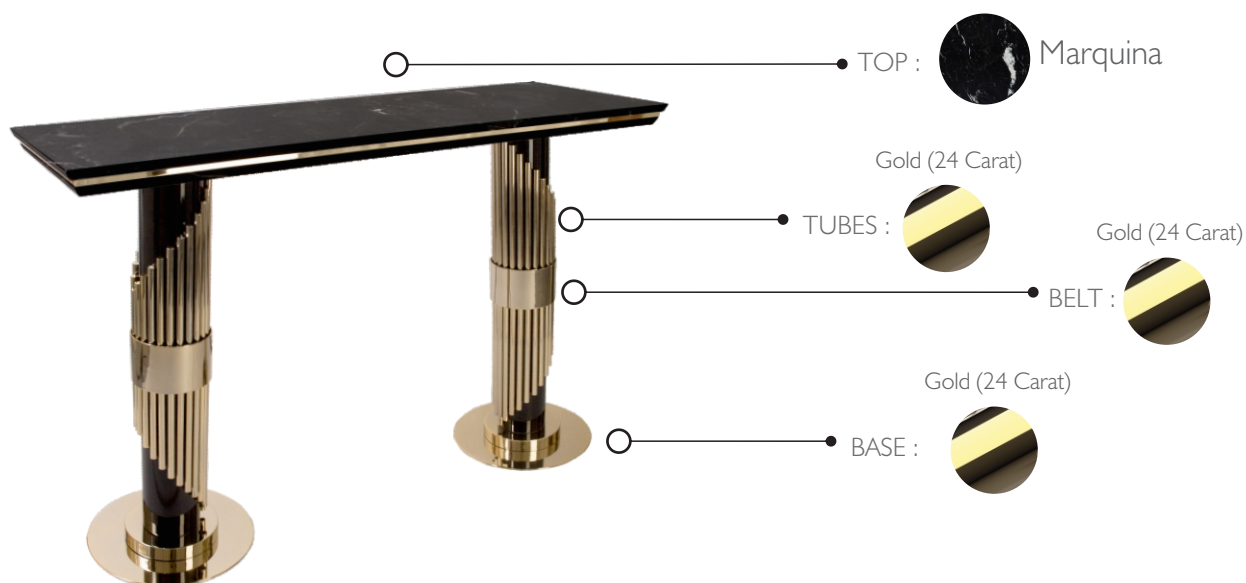

MORE FINISHES AVAILABLE HERE:  
[CLICK HERE](#) 